

# Timelines and delays in European grid expansion

Damiano Alessi, Behnam Zakeri, Kavita Surana

21 November 2025

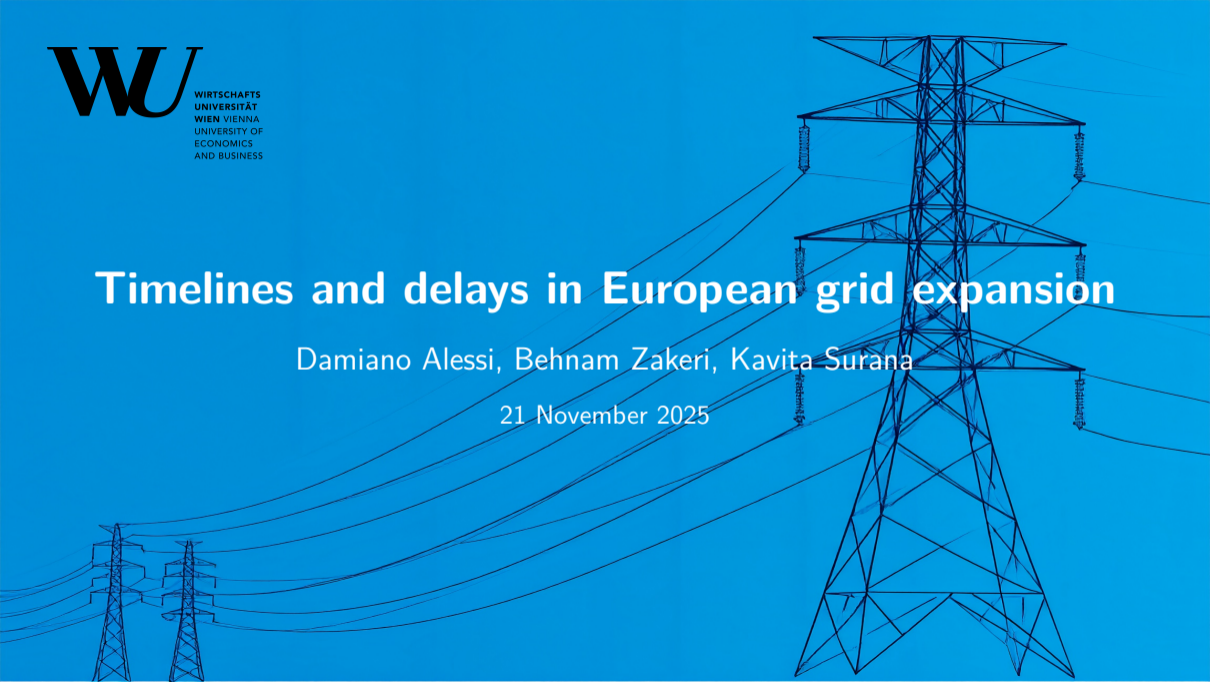

**A lengthy and uncertain permitting process for new power supply and grids is a major obstacle to faster installation of new capacity.**

Draghi, M. (2024). The Future of European Competitiveness

# Request of connection to the Italian transmission grid

Connection phase	Renewable Sources	Consumer Users
General Minimum Technical Solution to be accepted	39	30
General Minimum Technical Solution accepted	148	42
Projects under review	63	0.13
Projects with authorization	74	0.11
Definitive Minimum Technical Solution / Contract phase	10.5	4.23
<b>Total</b>	<b>336 (GW)</b>	<b>77 (GW)</b>

Source: Terna, Econnection Dashboard – Renewable and Consumer Users Connection Requests. Data updated to 31 October 2025.

# Research Questions

- **How long does it take to build a transmission line and which are the bottleneck?**
  - **1: Which factors mostly impact the duration?**  
*Analysis: Survival Analysis (Cox Model)*
  - **2: How often are projects delayed, and what factors most impact delays?**  
*Analysis: Linear Regression on Project Delay Data*
  - **3: Why are transmission projects delayed, according to official reports?**  
*Analysis: Semantic Clustering via K -Nearest Neighbors and Llama 3.2*

## Dataset: TYNDP (2010-2026)

- The Ten-Year Network Development Plan (TYNDP) is ENTSO-E's flagship planning document.
- Published biennially since 2010.
- Includes:
  - Priority infrastructure projects (PCI/PECI)
  - Cost-benefit analysis and scenario-based modeling
  - Needs for cross-border and national reinforcements
- Aims to mobilize €120 billion of investments by 2030.
- **919 unique investments** have been tracked across TYNDP editions from **2010 to 2026**

# Key technology components of electricity grids

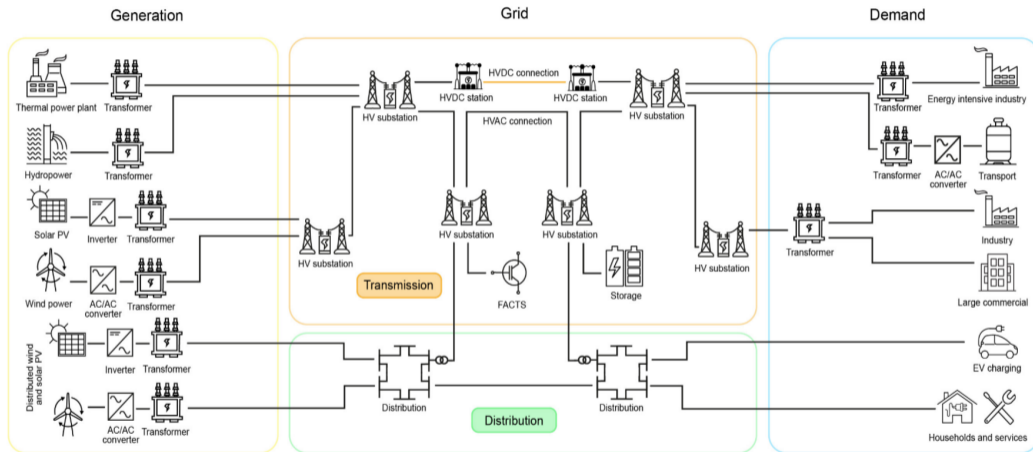

IEA. CC BY 4.0.

Source: IEA (2023), Electricity Grids and Secure Energy Transitions, IEA, Paris

# Structure of the Dataset

Year	Substation From	Substation To	Description	Status	Commissioning Progress	Year	Evolution Driver
2014	V.Minho	Feira [PT]	New double-circuit	Under consideration		2024	Although the construction started on the section Feira-Ribeira de Pena, there is a public opposition to the project that is delaying the construction. Section V.Minho-Ribeira de Pena was commissioned in 2021.
2014	MU [PT]		400kV	In planning but not permitting		Cancelled	
2016			OHL Vieira do	In permitting		Delayed	
2018			Minho (PT) -	Under construction		Rescheduled	
2020			Ribeira de Pena	Commissioned <sup>1</sup>		Investment on time	
2022			(PT) - Feira	Canceled		Ahead of time	
2024			(PT).			New investment	

Element type	Cross Border	New vs Renovation	Voltage Level [kV]	Capacity [MW]	Line Length [Km]
Reactive Compensation Device	Cross-border	New	220	1000	200
Transmission Line	Internal	Upgrade	330		
Offshore Substation			400		
Onshore Substation			500		
Transformer					

[1] Construction and commissioning covers the civil works, cable laying and, once the construction is over, the testing phase.

# How long does it take to build a transmission line in Europe

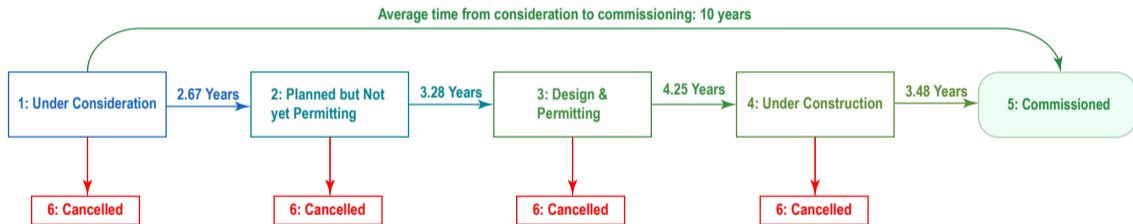

# 1: Multi-state Cox Model: Forward Transitions

## Preliminary results

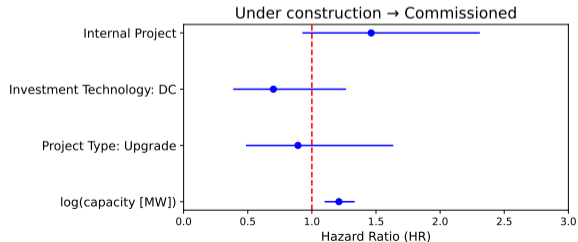
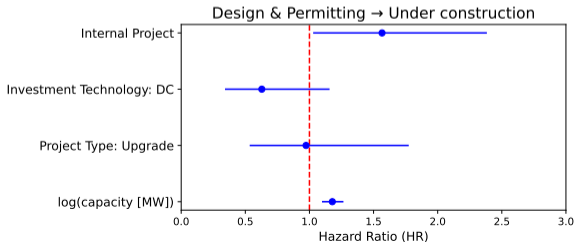
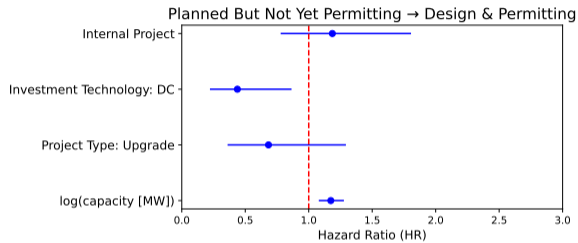
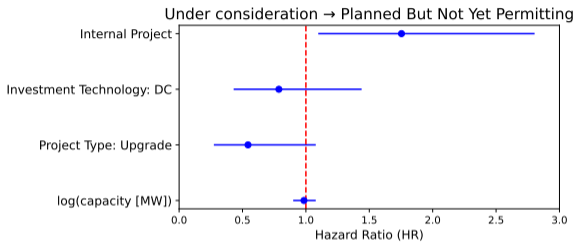

# 1: Multi-state Cox Model: Cancelled Transitions

## Preliminary results

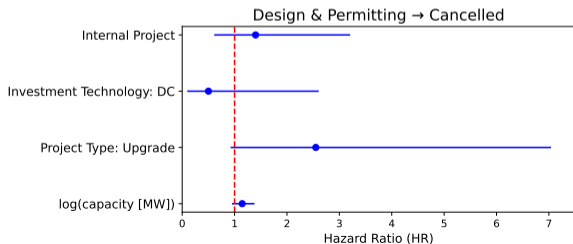
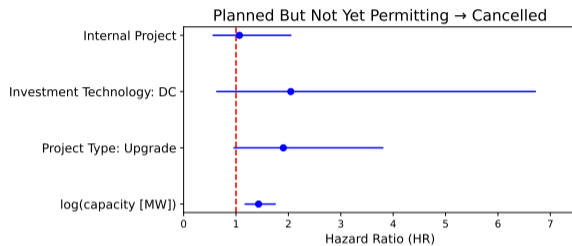
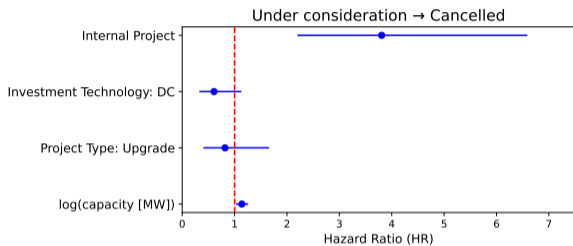

## 2: How often are investment delayed

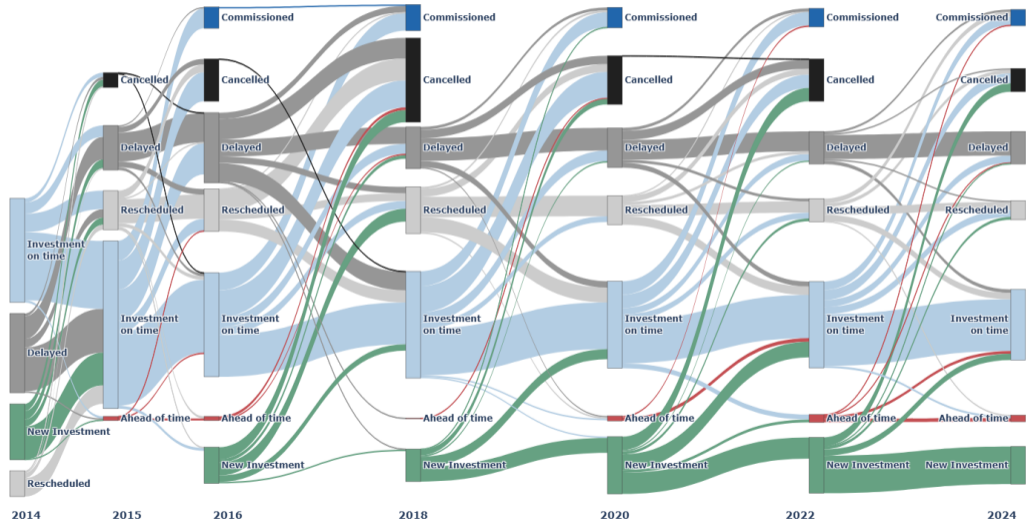

## 2: How often are investment delayed

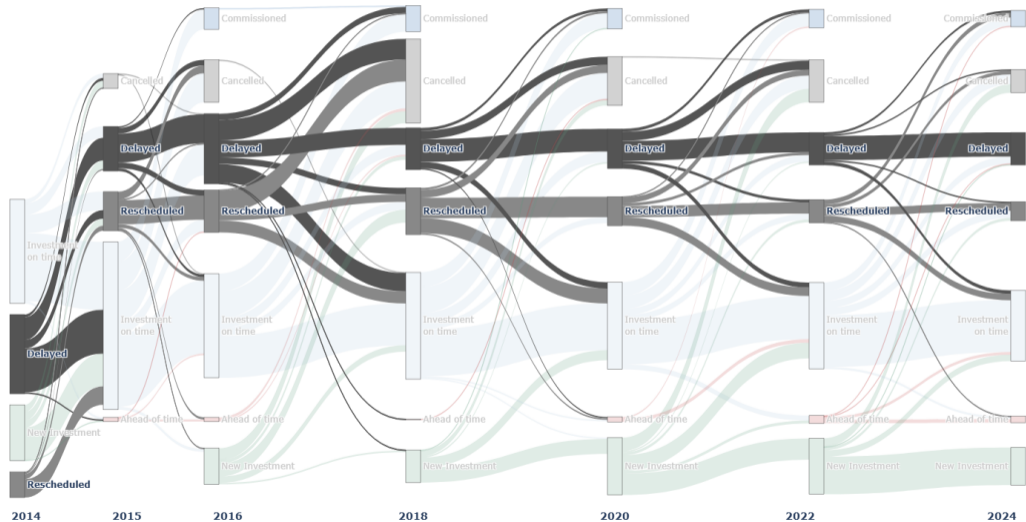

## 2: Distribution of Investment Delays (TYNDP)

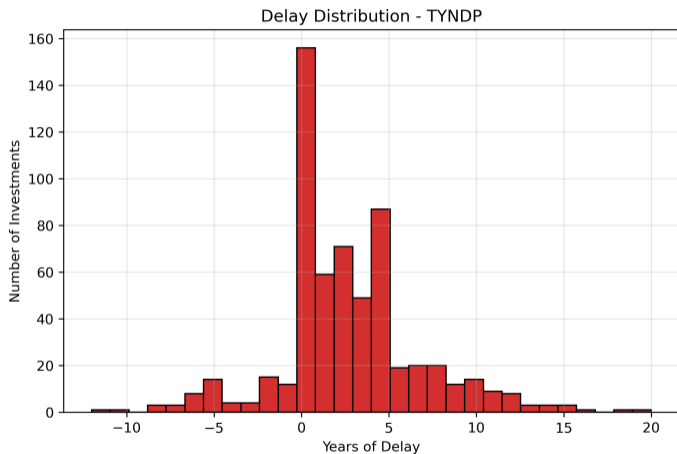

**Median delay (delay > 0): 4 years**    **Minimum delay: -12 years**    **Maximum delay: 20 years**

## 2: OLS Regression: Factors Affecting Delay (TYNDP)

R-squared: 0.085		F-statistic: 3.87		n = 515	
Variable	Coefficient	Std err	p-value		
Capacity [MW]	-0.0002	5.86e-05	0.005		
Technology: DC	+0.309	0.119	0.010		
New directive (Yes)	-0.43	0.096	0.000		
Domestic	+0.18	0.083	0.034		
Concluded: Commissioned	-0.44	0.124	0.000		

### 3: Causes of Delay: official TYNDP reports

Semantic Clustering via *K*-Nearest Neighbors and Llama 3.2

#### Llama 3.2 Clustering Results

---

External generation shifts	185	30%
Permitting	184	30%
Finance and land acquisition	41	6.5%
EIA process (Environmental Impact Assessment)	33	5.3%
Early stage study revision	16	3.3%
Progress as planned	15	2.5%
Demand forecast adjustment	2	0.3%
Residual	146	23%

---

# Contributions

- **Developed a unique, comprehensive dataset** covering all major transmission infrastructure projects in Europe (2010–2026).
- **Identified key drivers** impacting the construction phase and probability of project cancellation, based on advanced analysis of TYNDP data.
- **Conducted a deep-dive analysis on project delays**, combining regression and advanced semantic clustering (KNN Llama 3.2), highlighting that delays are mainly driven by permitting bottlenecks and market uncertainty.

## **Contact Information**

Damiano Alessi

Vienna University of Economics and Business

Institute for Data, Energy, and Sustainability

Department of Information Systems and Operations Management

damiano.alessi@wu.ac.at

## **Acknowledgments**

This work was supported by the BMIMI (Austrian Federal Ministry for Innovation, Mobility, and Infrastructure) through the BMINI endowed professorship for data-driven knowledge generation: climate change.